



PALLET RACK CATALOG
JUNE 2020

2020



PALLET RACK

COMPONENTS

- A** Upright Frames
- B** Beams
- C** Shelf Support
- D** Pallet Support
- E** Flat Wire Decking
- F** Particle Board Decking
- G** Waterfall Wire Decking
- H** Wall Tie
- I** Post Protector

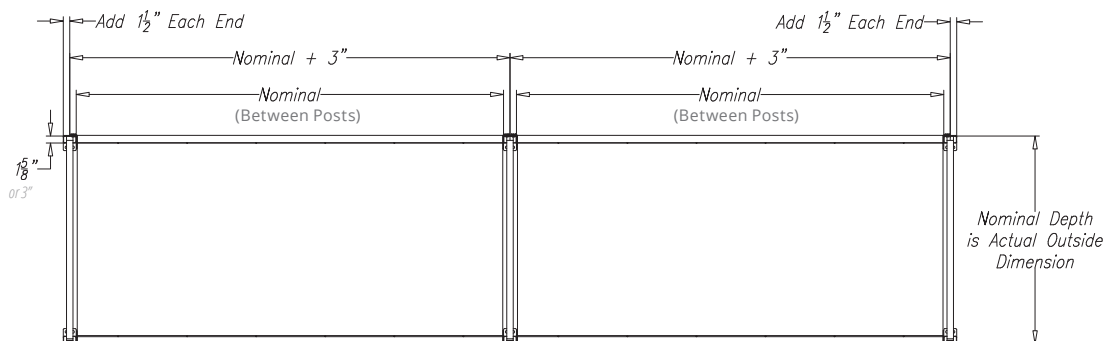

PALLET RACK UPRITE - STANDARD DUTY

- Tear Drop slotting is adjustable; every 2" on center
- Factory assembled fully welded construction
- Standard Duty Posts have 1 5/8" x 3" cross-sectional dimensions
- Welded footplate included; requires floor anchoring
- Anchoring hardware not included (ordered separately)

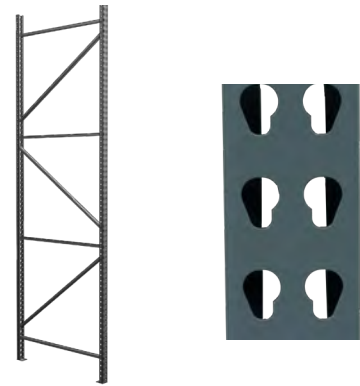

LBS Evenly distributed load of 17,000 lbs per Uprite Frame at 48" maximum vertical beam spacing

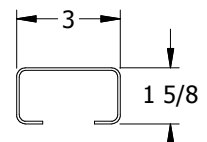

TOP PROFILE

Example Part #: **LPRU 36 048 S | QQ2**

1. **Lozier Pallet Rack Uprite: LPRU**
2. **Section Depth: 36", 42", 48"**
3. **Uprite Height: 048", 072", 096", 120"**
4. **Standard Duty: S**
5. **Pallet Rack Uprite Standard Finish: QQ2**

PALLET RACK UPRITE - HEAVY DUTY

- Tear Drop slotting is adjustable; every 2" on center
- Factory assembled fully welded construction
- Heavy Duty Posts have 3"x3" cross-sectional dimensions
- Welded footplate included; requires floor anchoring
- Anchoring hardware not included (ordered separately)

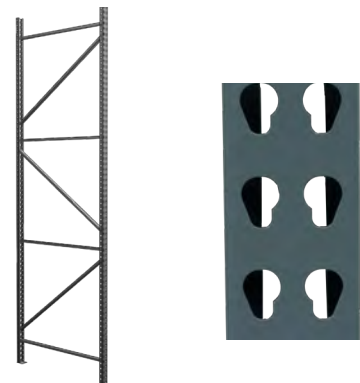

LBS Evenly distributed load of 27,000 lbs per Heavy Duty Uprite Frame at 48" maximum vertical beam spacing

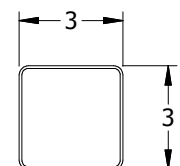

TOP PROFILE

Example Part #: **LPRU 42 096 H | QQ2**

1. **Lozier Pallet Rack Uprite: LPRU**
2. **Section Depth: 42", 48"**
3. **Uprite Height: 096", 120", 144", 168", 192"**
4. **Heavy Duty: H**
5. **Pallet Rack Uprite Standard Finish: QQ2**

SUFFIX KEY

S = Standard Duty

QQ2 = Gray

H = Heavy Duty

PALLET RACK TEAR DROP BEAM

- Available in multiple lengths and capacities
- Features a step design 1 5/8" deep with slots for incremental shelf support location
- 6" end clips have heavy duty rivets and a safety spring locking mechanism on the beam clip
- Beam lengths correspond with opening between upright posts

Example Part #: **TB 48 35 D FB | QQ2**

1. **Pallet Rack Tear Drop Beam: TB**
2. **Length: 48", 72", 93", 96", 99", 102", 108"**
3. **Height: 35, 45**
4. **Deep Step: D**
5. **Optional Floor Beam: FB**, Omit if not applicable
6. **Standard Finish: QQ2**

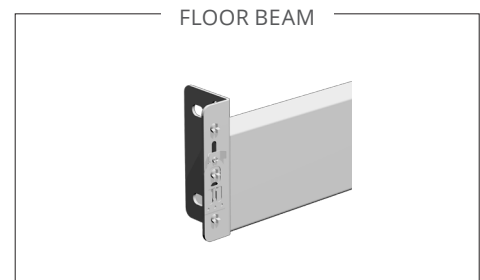
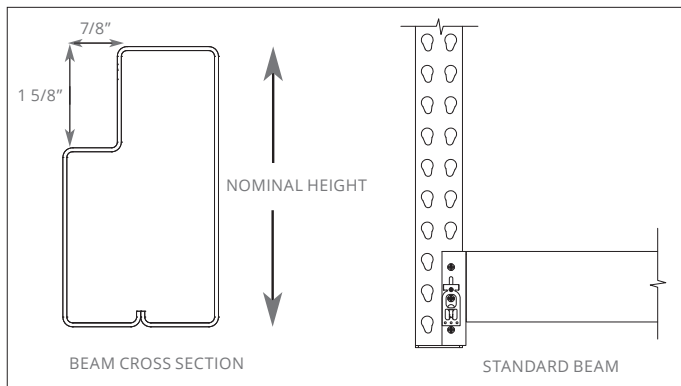
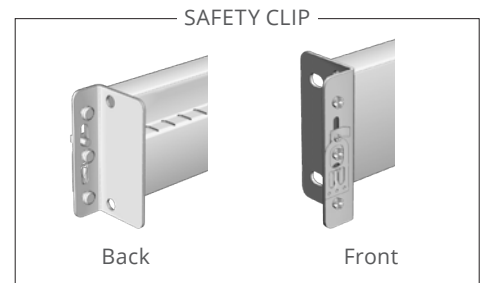
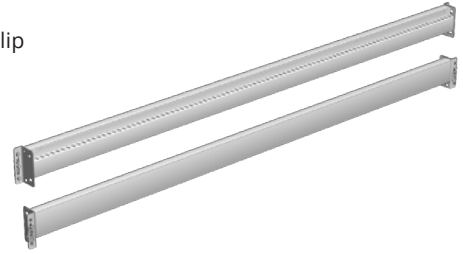

LENGTH	3.5" HIGH	4.5" HIGH
48"	7,600	10,000
72"	5,000	8,000
93"	3,850	6,400
96"	3,700	6,200
102"	3,400	5,800
108"	3,100	5,300

 Beam capacities based on even weight distribution

SUFFIX KEY

35 = 3.5" High

QQ2 = Gray

45 = 4.5" High

TEAR DROP BEAM SHELF SUPPORT

- Features “U” shaped design which hooks into slots in the pallet rack beams
- Required for all applications using load bearing shelves
- Nominal lengths correspond to nominal depths of conventional Pallet Rack Uprites

Example Part #: **TBSS 36** | **GLV**

1. **Tear Drop Beam Shelf Support: TBSS**
2. **Length: 36”, 42”, 48”**
3. **Standard Finish: GLV**

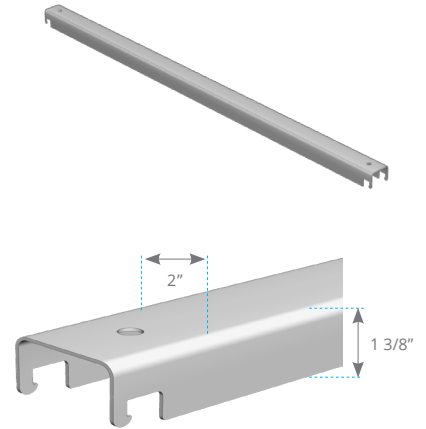

TEAR DROP BEAM SHELF SUPPORT - HEAVY DUTY

- Use for heavy duty applications
- Nominal lengths correspond to nominal depths of conventional Pallet Rack Uprites
- Not Available in GLV

Example Part #: **TBSSH 36** | **QQ2**

1. **Tear Drop Beam Shelf Support: TBSSH**
2. **Length: 36”, 42”, 48”**
3. **Standard Finish: QQ2**

 *Shelf Supports (in conjunction with particleboard/wire shelves) are required when levels are hand loaded or when palletized loads do not rest on front and back beams (or when pallets do not have sufficient strength to support the load in this fashion).*

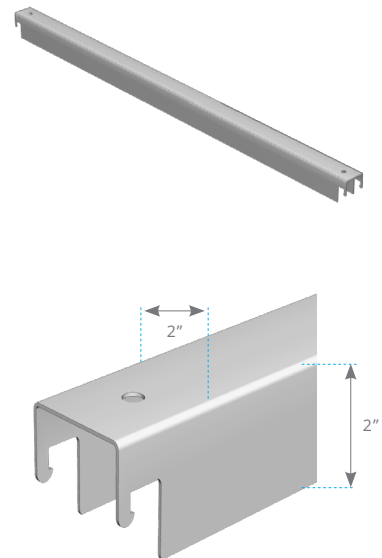

SUFFIX KEY

GLV = Galvanized

QQ2 = Gray

TEAR DROP BEAM SHELF SUPPORT



AVAILABLE CAPACITY ON FLAT WIRE OR PARTICLEBOARD DECKING USING THE NUMBER OF PALLET RACK SUPPORTS INDICATED (IN LBS)							
FRAME DEPTH	BEAM LENGTH	# OF TBSS SUPPORTS			# OF TBSSH SUPPORTS		
		3	4	6	3	4	6
36"	48"	2625	X	X	3000	X	X
	72"	2625	3500	X	3000	4000	X
	93"	X	3500	5250	X	4000	6000
	96"	X	3500	5250	X	4000	6000
	99"	X	3500	5250	X	4000	6000
	102"	X	3500	5250	X	4000	6000
	108"	X	3500	5250	X	4000	6000
42"	48"	2175	X	X	3000	X	X
	60"	2175	2900	X	3000	4000	X
	72"	X	2900	4350	X	4000	6000
	84"	X	2900	4350	X	4000	6000
	96"	X	2900	4350	X	4000	6000
	99"	X	2900	4350	X	4000	6000
	108"	X	2900	4350	X	4000	6000
48"	48"	1875	X	X	3000	X	X
	60"	1875	2500	X	3000	4000	X
	72"	X	2500	3750	X	4000	6000
	84"	X	2500	3750	X	4000	6000
	96"	X	2500	3750	X	4000	6000
	99"	X	2500	3750	X	4000	6000
	108"	X	2500	3750	X	4000	6000

Beam capacities based on even weight distribution

NOTE: The rated load capacity per pair of beams must be equal to or exceed the rated shelf capacity.

PALLET RACK FLAT WIRE DECKING

- Provides for light penetration, water flow through for sprinklers and cleanliness
- Each grid is one-piece, 3" x 3" pattern, with 5/16" diameter width wires and 1/4" diameter depth wires
- Clearances are provided for easy installation
- Order Shelf Supports separately

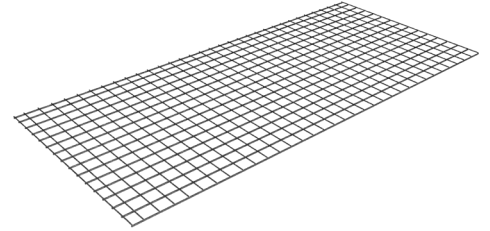



PALLET RACK PARTICLEBOARD DECKING

- Economical shelving material
- Features 5/8" thick industrial grade particleboard

Example Part #: **LPRWDF 36 48** | **ZNC**

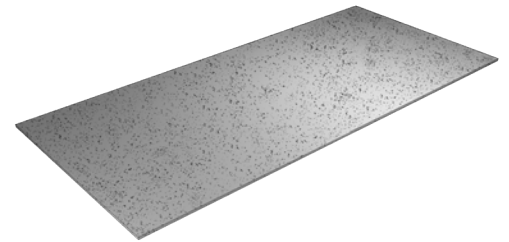
1. **Lozier Pallet Rack Deck: LPRWDF, LPRPB**
2. **Section Depth: 36", 42", 48"**
3. **Deck Length: 48", 72", 96", 99", 102", 108"**
4. **Pallet Rack Decking Standard Finish: ZNC, N/A**



 Nominal size corresponds to the depth of Pallet Rack Upright Frame & the length of the Pallet Rack Beam.

NOMINAL		ACTUAL DIMENSIONS	NOMINAL		ACTUAL DIMENSIONS
LENGTH	DEPTH		LENGTH	DEPTH	
48"	36"	32 5/16" x 45 1/4"	99"	36"	32 5/16" x 96 1/4"
	42"	38 5/16" x 45 1/4"		42"	38 5/16" x 96 1/4"
	48"	44 5/16" x 45 1/4"		48"	44 5/16" x 96 1/4"
72"	36"	32 5/16" x 69 1/4"	102"	36"	32 5/16" x 99 1/4"
	42"	38 5/16" x 69 1/4"		42"	38 5/16" x 99 1/4"
	48"	44 5/16" x 69 1/4"		48"	44 5/16" x 99 1/4"
93"	36"	32 5/16" x 90 1/4"	108"	36"	32 5/16" x 105 1/4"
	42"	38 5/16" x 90 1/4"		42"	38 5/16" x 105 1/4"
	48"	44 5/16" x 90 1/4"		48"	44 5/16" x 105 1/4"
96"	36"	32 5/16" x 93 1/4"			
	42"	38 5/16" x 93 1/4"			
	48"	44 5/16" x 93 1/4"			

SUFFIX KEY

LPRWDF = Flat Wire Decking

ZNC = Zinc Plated wire (Wire Decking only)

LPRPB = Particleboard Decking

N/A = No Finish (Particleboard Decking Only)

PALLET RACK WATERFALL WIRE GRID DECKING

- Provides for light penetration and water flow through for sprinklers and cleanliness
- 2.5" x 4" grid pattern
- Includes welded shelf supports
- Clearances are provided for easy installation

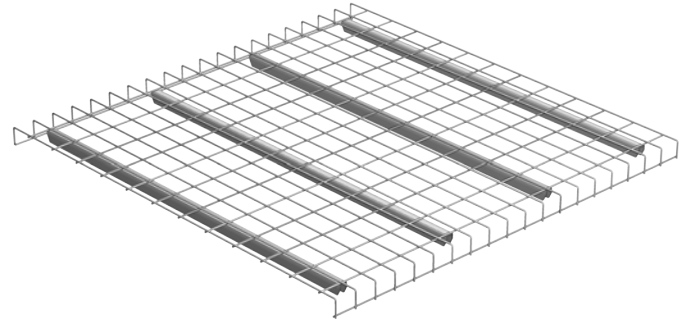

Example Part #: **WFG 36 46 M | XN6**

1. **Waterfall Grid: WFG**
2. **Upright Depth: 36", 42", 48"**
3. **Length: 46", 52"**
4. **System: M**
5. **Standard Finish: XN6**

CAPACITY	LBS		
	LENGTH	36"	42"
46"	2,700	2,700	2,500
52"	2,700	2,700	2,500

WATERFALL QTY/LENGTH PER BEAM LENGTH		
BEAM LENGTH	GRID LENGTH	QTY
48"	46"	1
93"	46"	2
96"	46"	2
102"	46"	2
108"	52"	2

NOMINAL		ACTUAL DIMENSIONS
LENGTH	DEPTH	
46"	36"	46 1/4" x 36 1/8"
	42"	46 1/4" x 42 1/8"
	48"	46 1/4" x 48 1/8"
52"	36"	51 1/4" x 36 1/8"
	42"	51 1/4" x 42 1/8"
	48"	51 1/4" x 48 1/8"

 Nominal size corresponds to the depth of Pallet Rack Upright Frame & the length of the Pallet Rack Beam.

NOTE: The rated load capacity per pair of beams must be equal to or exceed the rated shelf capacity.

SUFFIX KEY

M = Medium Duty

XN6 = Vendor supplied gray

TEAR DROP BEAM PALLET SUPPORT

- Features a flanged end design which wraps over the step beam and provides a support height flush with the beam top
- Suitable for supporting pallets on rack levels which do not require particleboard/wire shelves
- Two Pallet Supports are required per pallet
- Nominal lengths of Pallet Supports correspond to nominal depths of conventional Pallet Rack Uprites

Example Part # : TBSPS 36 | QQ2

1. **Tear Drop Beam Pallet Support: TBSPS**
2. **Length: 36", 42", 48"**
3. **Standard Finish: QQ2**

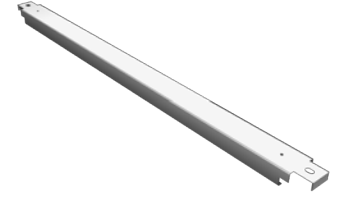

PALLET RACK UPRITE POST PROTECTOR

- Provides extra protection against abuse from material handling vehicles
- Not usable with a beam located within 18" or 24" of the floor
- Requires floor anchoring
- Anchoring hardware not included (ordered separately)

Example Part # : LPRUPP 18 | QQ2

1. **Pallet Rack Uprite Post Protector: LPRUPP**
2. **Height: 18", 24"**
3. **Standard Finish: QQ2**



SUFFIX KEY

QQ2 = Gray

PALLET RACK WALL TIES

- Wall Ties are used to maintain proper spacing from a wall or for additional stability
- Uprites up to 96" tall require 2 Ties per Uprite
- Uprites over 96" tall require 3 Ties per Uprite
- Hardware to attach Wall Tie to the Uprite Frame included

Example Part # : LPRWT 2L | QQ2

1. **Pallet Rack Wall Ties: LPRWT**
2. **Length: 2L, 6L, 12L**
3. **Standard Finish: QQ2**



PALLET RACK ROW SPACER

- Row Spacers are used to maintain proper spacing between back-to-back runs
- Required on all back-to-back runs that have height to depth ratio of 6:1 or greater
- Uprites up to 96" tall require 2 spacers per Uprite
- Uprites over 96" tall require 3 spacers per Uprite
- Hardware included

Example Part # : LPRRS 2L | QQ2

1. **Pallet Rack Row Spacer: LPRRS**
2. **Length: 2L, 3L, 6L, 8L**
3. **Standard Finish: QQ2**

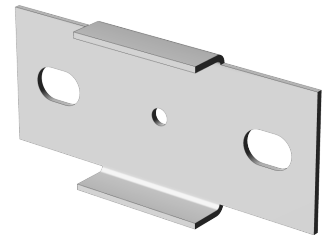

SUFFIX KEY

2L = 2" Long

3L = 3" Long

6L = 6" Long

8L = 8" Long

12L = 12" Long

QQ2 = Gray

REPLACEMENT PALLET RACK SAFETY CLIP

- Replace damaged or worn safety clip
- Helps secure pallet racks and beams for added safety

Example Part #: **PRBCLIP** | **ZNC**

1. Pallet Rack Safety Clip: **PRBCLIP**
2. Standard Finish: **ZNC**

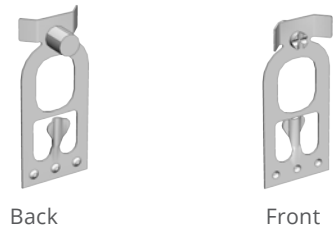

PALLET RACK UNIVERSAL SAFETY J-PIN

- Safety Pins offer a secure safety connection from Beam to Upright Frame
- Universal fit
- Easy to install
- Zinc coated

Example Part #: **PRJPIN** | **N/A**

1. Pallet Rack Universal J-Pin: **PRJPIN**
2. Standard Finish: **N/A**



SUFFIX KEY

ZNC = Zinc Plated

N/A = No Finish

PALLET RACK VERTICAL M DIVIDER

- Vertical divider for large products
- Two saddle brackets slide over rear beam; bolt underneath beam (hardware included)
- Compatible with multiple beam heights

Example Part #: PRVMD 42 48 | QQ2

1. Pallet Rack Vertical M Divider: PRVMD
2. Depth: 18", 30", 36", 42"
3. Height: 24", 36", 48"
4. Standard Finish: QQ2



TEAR DROP BEAM GARDEN ARM

- Saddle brackets slide over rear beam; bolt underneath beam (hardware included)
- Sizes vary for storage of any handled item or as a simple divider
- Arm welded to bracket on an upward angle
- Flat plate on front for label

Example Part #: TBGA 18 S | QQ2

1. Tear Drop Beam Garden Arm: TBGA
2. Depth: 18", 24", 30", 36", 42"
3. Systems: S, D
4. Standard Finish: QQ2



Single

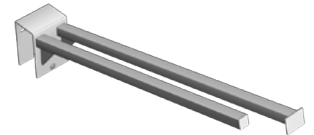

Double

PALLET RACK SLIDING DIVIDER

- Use with Pallet Rack Particle Board Decking (LPRPB)

Example Part #: PRSD 36 09 | QQ2

1. Pallet Rack Sliding Divider: PRSD
2. Depth: 24", 36", 42", 48"
3. Height: 06", 09"
4. Standard Finish: QQ2, GLV

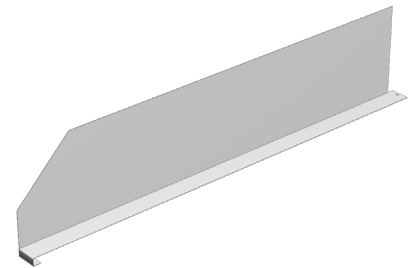

SUFFIX KEY

QQ2 = Gray

D = Double

S = Single

GLV = Pre-Galvanized



MARCH 2020

LOZIER.COM | 6336 PERSHING DR. OMAHA, NE 68110 | (800) 228-9882 • (402) 457-8000