

INSTALLATION INSTRUCTIONS

EXTENSION UPRITE (U_E & UH_E)

WARNING

1. THE UNBALANCED LOAD ON EXTENSION UPRITES MUST NOT EXCEED 2500 INCH-POUNDS. **(SEE PAGE 5 OF 6)**
2. EXTENSION UPRITES MUST BE SECURELY FASTENED INTO THE UPRITES BELOW. **(SEE STEP 5 FOR METHOD)**
3. THE HEIGHT OF THE UPRITE (INCLUDING EXTENSION UPRITES, IF ANY) MUST NOT EXCEED THE LEVELER SPACING BY A RATIO OF 6:1 WHEN ANCHORED. **(SEE PAGE 6)**
4. IF INSTALLING AN EXTENSION ONTO A FIXTURE THAT HAS OFFSET END MERCHANDISING PANELS (OEMP'S) CURRENTLY INSTALLED, REMOVE ALL MERCHANDISE FROM OEMP BEFORE REMOVING OR INSTALLING ANY TOP RAILS FROM SHELVING BEHIND. FAILURE TO DO SO CAN CAUSE PERSONAL INJURY AND DAMAGE TO THE FIXTURE COMPONENTS.
5. WHEN INSTALLING TOP RAILS, MAKE SURE THAT THE TOP RAIL LOCKING TABS ARE SECURELY ENGAGED INTO THE UPRITE LANCES. IF THE TOP RAIL IS NOT SECURELY ENGAGED OR DISENGAGES EASILY, THEN THE TOP RAIL MUST BE REPLACED BEFORE REMERCHANDISING THE FIXTURE AND THE OEMP.
6. OEMP'S SHOULD NEVER BE ATTACHED DIRECTLY TO UPRITE EXTENSION. OEMP'S SHOULD ONLY ENGAGE INTO THE PRIMARY UPRITE BELOW. THE EXTENSION IS NOT CAPABLE OF TAKING THE LOADS CAUSED BY THE OEMP. ENGAGING THE EXTENSION DIRECTLY CAN CAUSE PERSONAL INJURY OR PROPERTY DAMAGE.
7. NEVER INSTALL AN EXTENSION UPRITE INTO ANOTHER EXTENSION UPRITE. STACKING EXTENSIONS COULD CREATE A DANGEROUS SITUATION LEADING TO PERSONAL INJURY OR PROPERTY DAMAGE.
8. DO NOT USE WITH WALL END STABILIZERS, UNLESS THE STABILIZER IS SPECIFICALLY DESIGNED FOR USE WITH UPRITE EXTENSIONS.

STEP 1: REMOVE TOP CAP FROM EXISTING UPRITE. (**FIGURE 1**)

STEP 2: INSERT EXTENSION UPRITE INTO EXISTING UPRITE. (**FIGURE 2**)

STEP 3: LINE UP EXTENSION UPRITE WITH EXISTING UPRITE. (**FIGURE 3**)

NOTE: MAKE SURE THAT THE EXPANDING CONNECTOR DOES NOT BLOCK SLOTS OF EXISTING UPRITE.

STEP 4: IF A SHELF, DOORKIT END TRIM, END PANEL, OR OTHER COMPONENT IS TO BE LOCATED AT THE JOINT BETWEEN THE EXTENSION AND THE EXISTING UPRITE, ADJUST THE GAP TO MAINTAIN STANDARD FUNCTION. PLACE A 3/4" GAP BETWEEN THE TOP OF THE BOTTOM SLOT OF THE EXTENSION AND TOP OF THE UPRITE. A PENNY MAY BE USED AS A GAUGE TO SET THIS 3/4" GAP. (**FIGURE 4, DETAIL A**)

STEP 5: TIGHTEN BOTH LOWER SET SCREWS SHOWN AS 1 & 2 IN FIGURE 5 (**SEE WARNING NOTE 2**). DO NOT ADJUST THE UPPER EXTENSION SET SCREW ON EXTENSION UPRITES. REPLACE TOP CAP. (**FIGURE 5**)

STEP 6: REPEAT STEPS 1-5 FOR SECOND SET OF UPRITES.

INSTALLATION INSTRUCTIONS

EXTENSION UPRITE (U_E & UH_E)

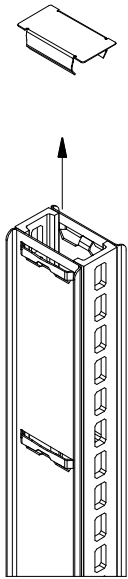

FIGURE 1

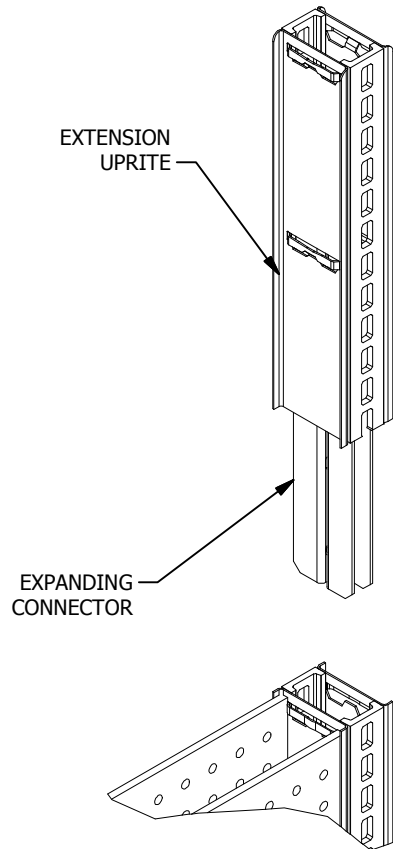

FIGURE 2

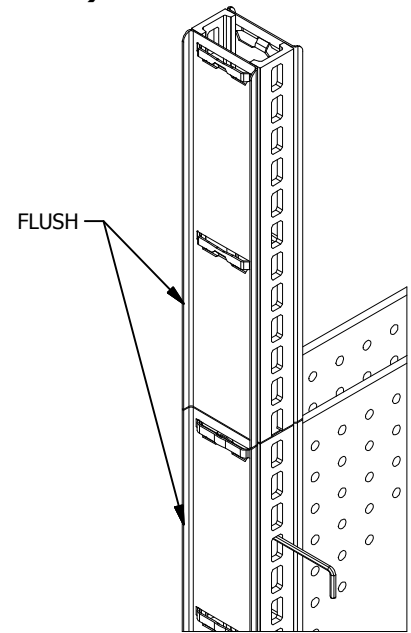

FIGURE 3

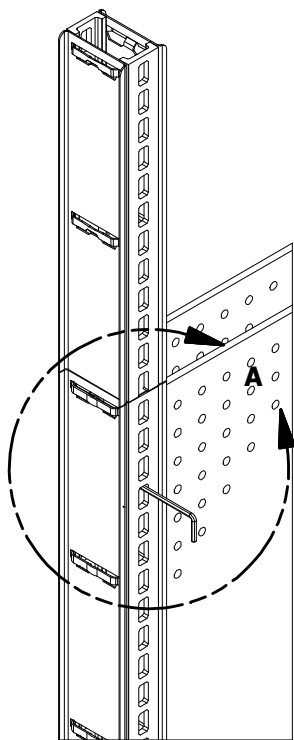
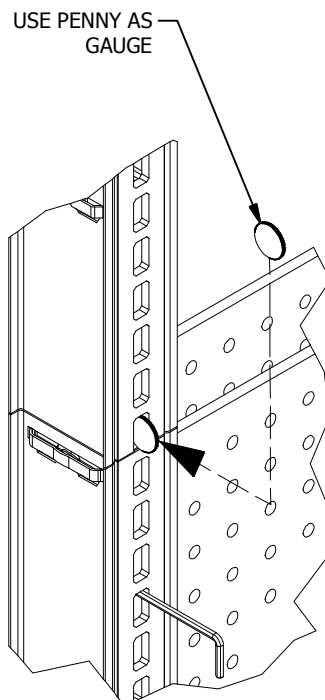

FIGURE 4



DETAIL A

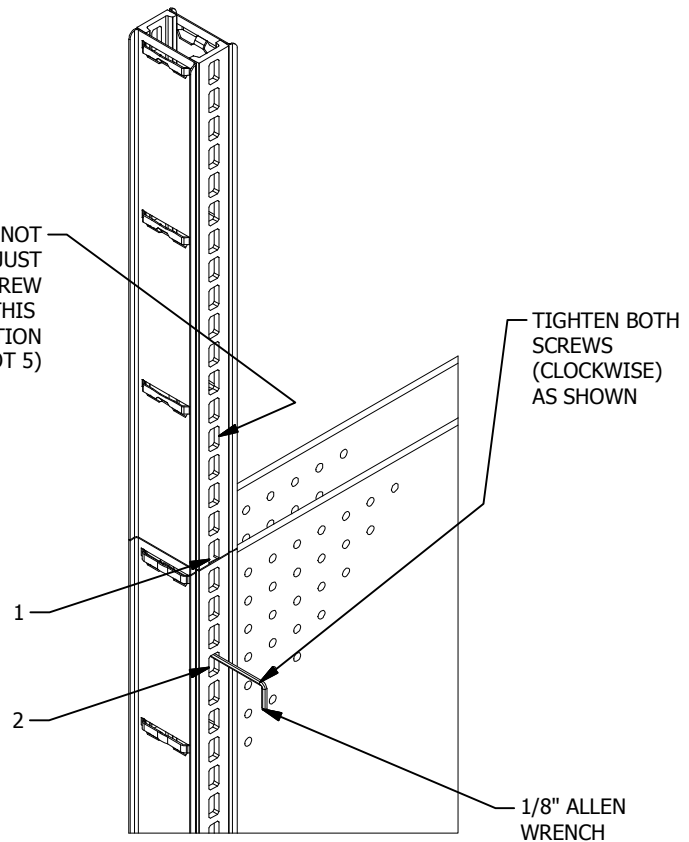

FIGURE 5

INSTALLATION INSTRUCTIONS

EXTENSION UPRITE (U_E & UH_E)

STEP 7: LAY TOP RAIL (R_T) UPSIDE DOWN ON TOP OF EXISTING TOP RAIL. **(FIGURE 7)**

OPTIONAL: REMOVE (R_T) AND REPLACE WITH (R_S). THE (R_T) CAN BE USED AT THE TOP OF THE EXTENSION UPRITES.

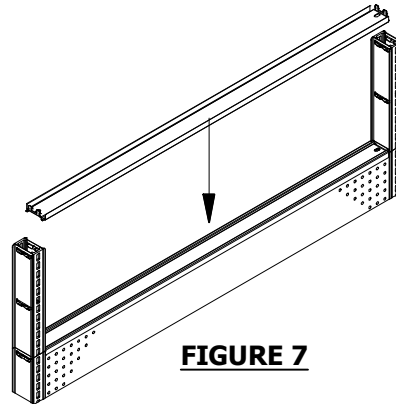

STEP 8: INSTALL FIRST EXTENSION BACK PANEL (BE____) BY SLIDING IN FROM TOP OR BOWING IN FROM FRONT. **(FIGURE 8)**

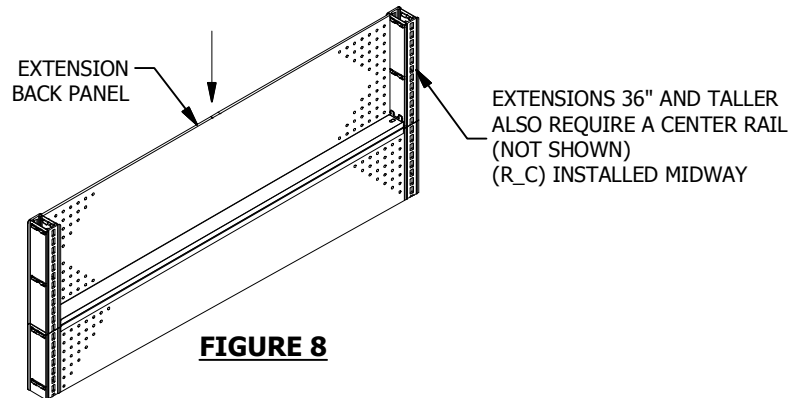

STEP 9. INSTALL SECOND EXTENSION BACK PANEL (BE____). **(FIGURE 9)**

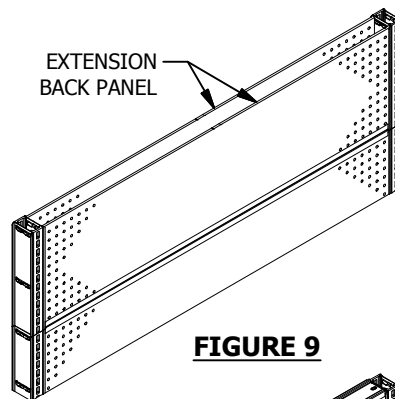

STEP 10. INSTALL TOP RAIL (R_T). **(SEE FIGURE 10)**

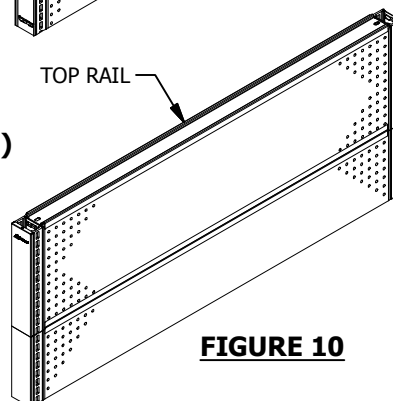

INSTALLATION INSTRUCTIONS

EXTENSION UPRITE (U_E & UH_E)

STEP 11: INSTALL SHORT EXTENSION UPRITE END TRIM AS SHOWN.

STEP 12: RE-INSTALL TALL UPRITE END TRIM UPSIDE DOWN. **(SEE FIGURE 11)**
SLIDE UPWARD TO REMOVE GAP BETWEEN UPRITE AND EXTENSION UPRITE AS SHOWN.

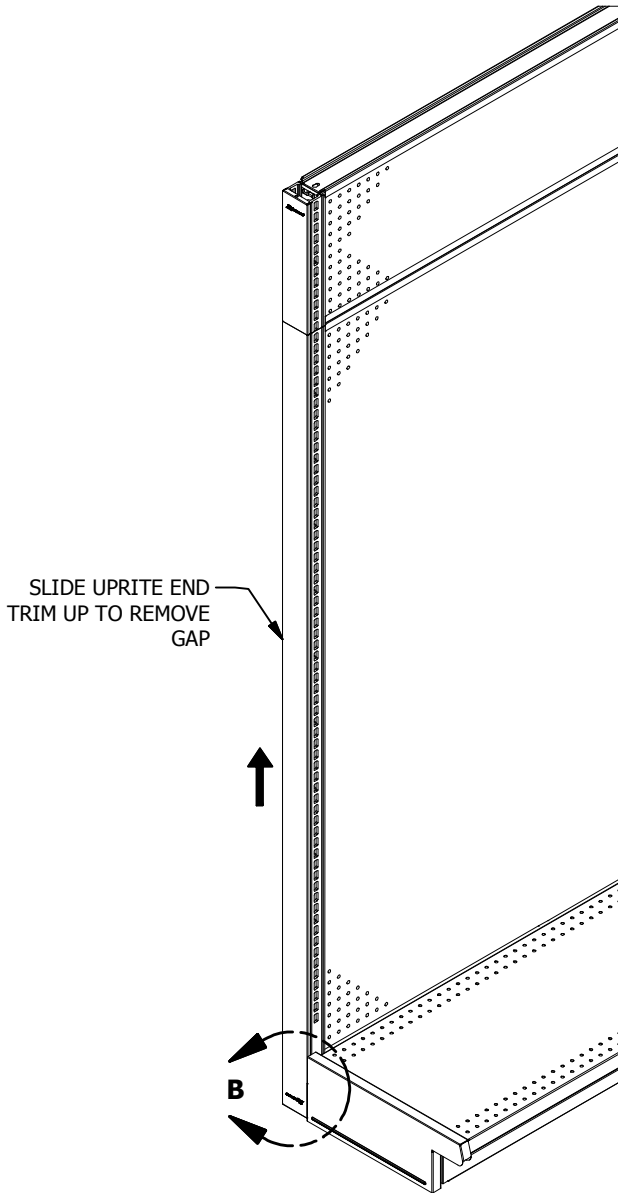
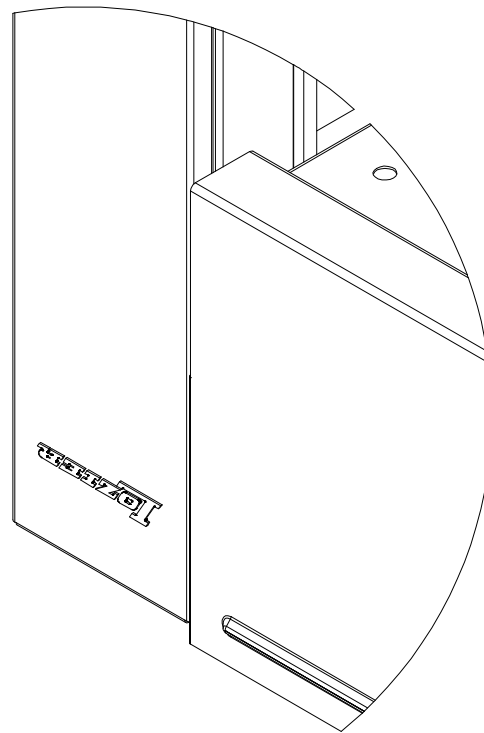

FIGURE 11



DETAIL B

INSTALLATION INSTRUCTIONS

EXTENSION UPRITE (U_E & UH_E)

HOW TO CALCULATE UNBALANCED LOAD ON EXTENSION UPRITE

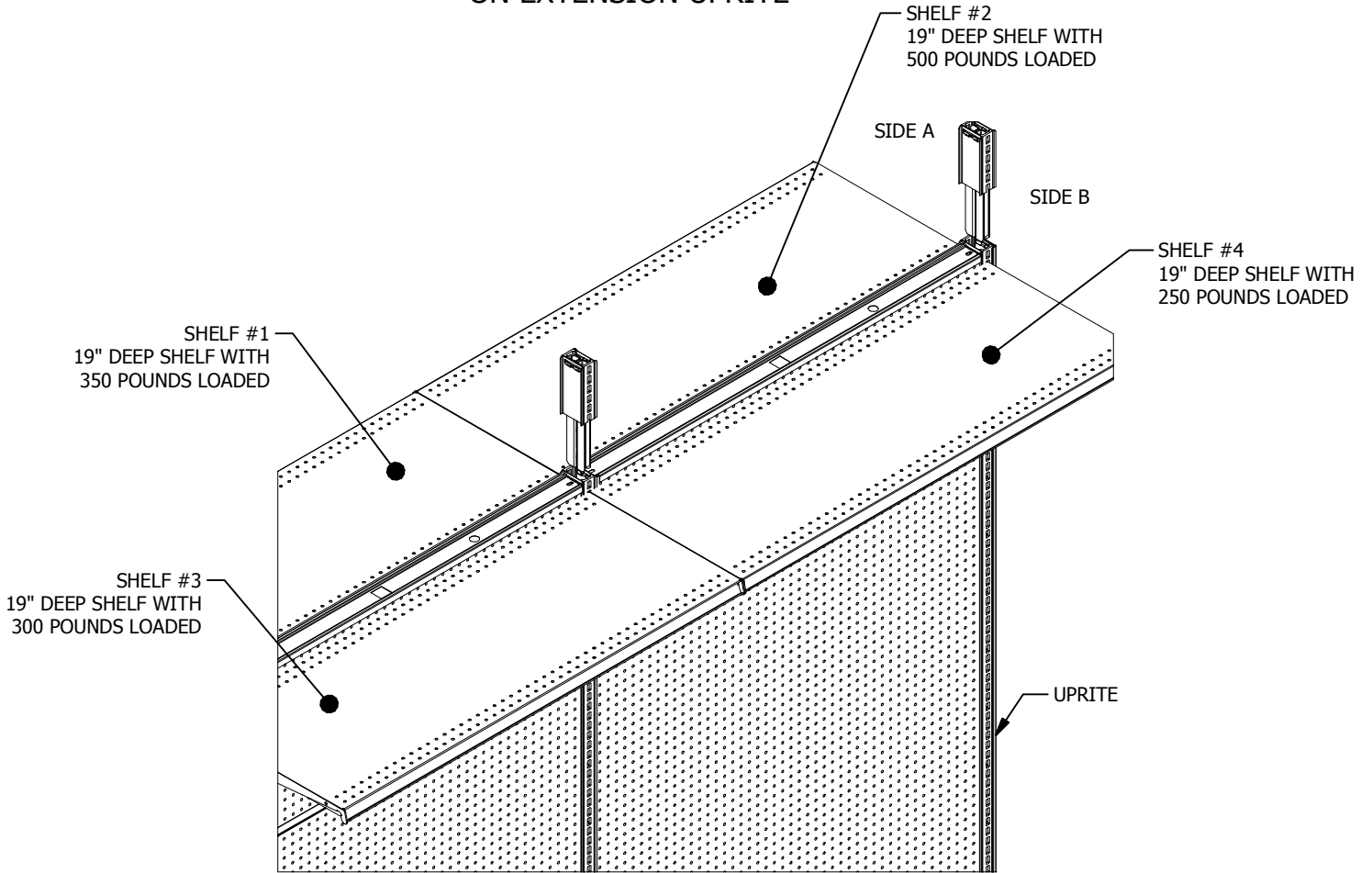

FIGURE 12

NOTE: SHELF SIZES AND WEIGHTS ARE FOR EXAMPLE ONLY. THIS INFORMATION IS TO BE REFERENCED ON THE SAMPLE CALCULATION SHOWN BELOW.

FOLLOW THIS FORMULA FOR CALCULATING INCH POUNDS FOR EACH SHELF \times DEPTH OF SHELF \div WEIGHT ON SHELF $\times 4 =$ IN-LBS PER END OF SHELF

<u>SIDE A</u>		<u>SIDE B</u>	
SHELF #1 = 19 X 350 \div 4 =	1662.5 IN-LBS	SHELF #3 = 19 X 300 \div 4 =	1425 IN-LBS
SHELF #2 = 19 X 500 \div 4 =	<u>2375 IN-LBS</u>	SHELF #4 = 19 X 250 \div 4 =	<u>1187.5 IN-LBS</u>
TOTAL =	4037.5 IN-LBS	TOTAL =	2612.5 IN-LBS
SUBTRACT SMALLER TOTAL FROM LARGER TOTAL.	4037.5 -2612.5 1425	NOTE: THE TOTAL UNBALANCED LOAD INCLUDING ALL SHELVES ABOVE AND BELOW EXTENSION UPRITE SPLICE MUST NOT EXCEED 12,000 INCH-POUNDS FOR BB06'S AND 15,000 INCH-POUNDS FOR BBL'S. DECK LOAD DOES NOT AFFECT UNBALANCED LOAD. REFER TO BASIC SHELVING INSTRUCTIONS (01-13).	
THIS IS TOTAL UNBALANCED LOAD ABOVE THE 1ST EXTENSION UPRITE SPLICE AND MUST NOT EXCEED 2,500 INCH POUNDS			

INSTALLATION INSTRUCTIONS

EXTENSION UPRITE (U_E & UH_E)

SPECIAL WARNINGS:

EXTENSION UPRITES - The maximum unbalanced load on shelves above the joint on an Extension Uprite should not exceed 2500 inch-pounds. Exceeding this maximum load may cause shelving to tip over resulting in personal injury or property damage.

PEGBOARD BACK LOADS - The load applied to pegboard Backs with a standard Bottom Rail should not exceed 150 lbs. in total, 50 lbs. in any single square foot area, or 10 lbs. per hook. With heavy duty Bottom Rails, the load applied should not exceed 350 lbs. in total, 50 lbs. in any single square foot area, or 10 lbs. per hook. Excessive loading of Pegboard Backs can cause the Backs to fracture and/or become dislodged which could result in personal injury to employees or customers, damage to property, or damage to the fixture itself.

MAXIMUM SECTION LOAD - The maximum load placed on one section shall not exceed 4,500 lbs. This maximum shall include the combined weight placed on backs, shelves and decks, including both sides of an Island section.

OVERTURNING WARNINGS:

WARNING! Failure to follow these instructions and warnings may result in overturning or collapse of the fixture, resulting in personal injury to your employees or customers, damage to property, or damage to the fixture itself.

To help avoid overturning:

- The height of the Uprite (including Extension Uprites, if any) must not exceed the leveler spacing by a ratio of 6:1 when unanchored (see the charts). CAUTION: Tall unanchored Island Sections using 13"-16" bases and heavily loaded on one side must not exceed the following load limits:
 - 13" base with Uprite height greater than 78" unbalanced load not to exceed 6,000 in-lbs
 - 16" base with Uprite height greater than 102" unbalanced load not to exceed 6,000 in-lbs
- If Uprites on Wall Sections exceed the heights listed, the Base Bracket and the Uprite levelers must be anchored to the floor or otherwise braced.
- Base Brackets of free-standing Wall Sections must be anchored to prevent backward tipping. If Uprite height to leveler spacing exceeds 6:1 the Base Brackets and Uprites must be anchored.
- Contact local building official for anchoring requirements in seismic zones.
- Maximum shelf depth **cannot** exceed Base Deck depth.
- Do **not** hang Peg Hooks, Shelves, or other accessories on the back side of a Wall Section or any section without Base Brackets. Wall Sections do not have Base Brackets on the back side to provide support, and use of the back side to display merchandise may cause the section to tip over.
- Do **not** lean tall or heavy items against shelving unless shelving is anchored to a suitable building wall, to the floor, or otherwise braced to prevent overturning. The weight and force of leaning items on unanchored or unbraced shelving may cause the shelving to overturn or collapse.

Flooring Anchoring

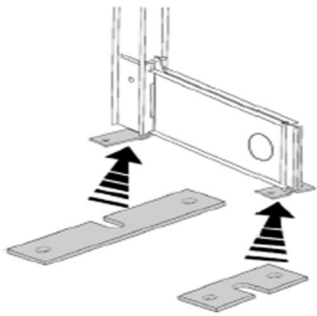

Important Notice for Free Standing Units

- If glass Doorkits are used on Wall Section or on one side only of Island Section, reduce maximum height by 12"
- If fixture is on carpet, reduce maximum height by 12"
- Anchor Base Brackets of Wall Sections regardless of Uprite height

WALL

BASE SIZE	LEVELER SPACING(A)	TALLEST UNANCHORED UPRITE
13"	9 3/4"	54"
16"	12 3/4"	72"
19"	15 3/4"	90"
22"	18 3/4"	108"
25"	21 3/4"	120"
28"	24 3/4"	144"

NOTE: For Uprite applications taller than 144" contact Marketing.

ISLAND

BASE SIZE	LEVELER SPACING(B)	TALLEST UNANCHORED UPRITE
13"/13"	19 1/2"	114"
13"/16"	22 1/2"	132"
13"/19"	25 1/2"	144"
16"/16"	25 1/2"	144"

NOTE: For Uprite applications taller than 144" contact Marketing.

WALL SECTION

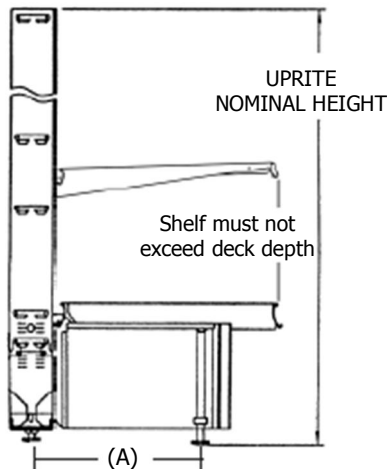

ISLAND SECTION

